

Part number

CMAO 16.21



Brief description:

hoods for two levers, size "104.27" insulated 830V version, side entry, Pg21, insulated 830V version, IP66 (EN 60529) and IP69K (DIN 40050 - 9) degree of protection.

Product description	
Version	insulated 830V version
Series	Hoods with 4 pegs
Product type	with 4 pegs
Variant	side entry
Style	high construction
Family	830V enclosures for CME inserts
Size	size "104.27" insulated 830V version
Technical data	
Material	metal
IP degree of protection	IP66 (and IP69K DIN 40050 - 9)
Cable entry	Pg21
Further technical details	
Weight	243,00 g

Approvals / Standards	
Quality mark	UL (type:4/4X/12), CE, EAC
Conformity	CQC, CE
General ordering information	
EAN13 code	8015747028912
Tariff number	85369095
Packaging Information	
Sub-packaging weight	1,22 kg
Sub-packaging description	Plastic packaging
Sub-packaging quantity	5 Pcs
Sub-packaging EAN barcode	8015747028929

Part number

CMAO 16.21



Catalogue drawings

**CMO [CMAO] CMV (CMAV) - MMO [MMAO]
MMV (MMAV)**

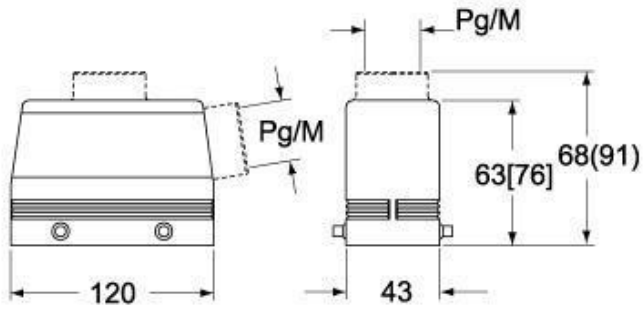

CMV G (CMAV G) - MMV G (MMAV G) - [MMFV G]

